

MODEL 738LS LIGHT DUTY LINE SHAFT DRIVEN LIVE ROLLER

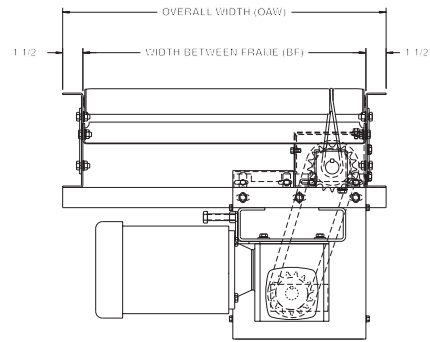

Conveyor shown with optional supports

Model 738LS has gained widespread usage with its unique design. Curves, spurs and a number of accessories may be driven by a SINGLE drive.



BF	10"	16"	22"
OAW	13"	19"	25"
LENGTH	UNIT WEIGHTS (lbs.) WITH 1-1/2" ROLLER CENTERS*		
2'	224	232	239
10'	399	459	515
20'	604	750	859
30'	838	1035	1194
40'	1058	1322	1532
50'	1278	1610	1871
60'	1498	1897	2209
70'	1717	2185	2548
80'	1937	2473	2887
90'	2156	2760	3249
100'	2376	3048	3590

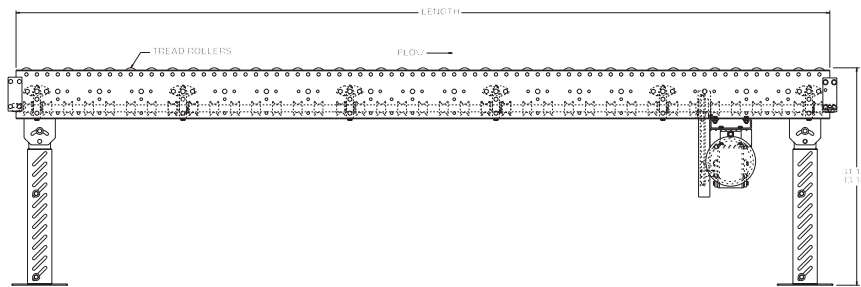

SPECIFICATIONS

TREAD ROLLERS: 1-3/8" dia. x 18 ga. galvanized steel, model 138G w/ 5/16" hex, grooved.

DRIVE BELT: 1/8" dia., polyurethane belts. Nominal 10 lbs. per roller drive.

DRIVE SHAFT: 1" dia. C1018 cold rolled steel shaft.

COUPLINGS: Couplings located both ends (type "A"), one end only (type "B" or "C") or none (type "D"). See 'line shaft coupling chart' on page 74 & specify.

CENTER DRIVE: Reversible drive; located approx. 18" from end of bed section for 3" and 6" RC; 16-1/2" for 4" RC.

BED: 7" x 1-1/2" x 12 ga. formed steel channel frame. Bed sections attached w/ splice plates and floor supports.

SPEED: 60 FPM, constant.

BEARINGS: Precision, lubricated, ball bearing units with composite housings.

MOTOR DRIVE: 1/3 HP, 230/460/3, 60 cycle, ODP right angle gear motor.

ROLLER CHAIN: Drive shaft is driven by No. 50 chain. Chain take-up provided on motor base.

CAPACITY: See Technical Section for load capacity rating.

ELECTRICAL CONTROLS: Optional.

HP @ 60 FPM	"A" MAX.
1/3, 1/2	21"
3/4, 1	22"
1-1/2, 2	23"

*For other centers, deduct the following (RC/lbs. per ft.):
10" BF--3" RC/4 lbs.; 4" RC/5 lbs.; 6" RC/6 lbs.
16" BF--3" RC/6 lbs.; 4" RC/7.5 lbs.; 6" RC/9 lbs.
22" BF--3" RC/8 lbs.; 4" RC/10 lbs.; 6" RC/12 lbs.

OPTIONAL EQUIPMENT

SIDE MOUNTED DRIVE: With 10" minimum elevation.

FLOOR SUPPORTS: Supports, knee braces, casters, polytier supports & ceiling hangers available. See Conveyor Accessories.

SPEED: Constant 15-120 FPM, or variable (specify). MINIMUM operating speed for line shaft conveyor is 15 FPM. **NOTE: CAPACITY CHANGES WITH SPEED.**

MOTORS: Available through 2 HP in TEFC, explosion proof, dirty duty, 115/230/1, 575/3.

ELECTRICAL CONTROLS: Manual start/stop push button switch; magnetic starter; others available.



MODEL 738LSC LIGHT DUTY LINE SHAFT DRIVEN CURVE MODULE



Conveyor shown with optional supports

Model 738LSC features tapered rollers to help product maintain orientation. NO drive is required since it is designed to be driven from 738LS straight line shaft driven sections and includes close roller centers as a standard feature.

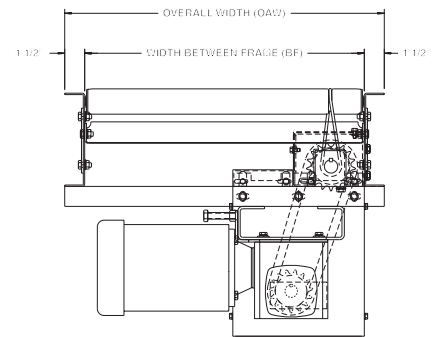

CURVE	90°	60°	45°	30°
BF	WT. (lbs.)	WT. (lbs.)	WT. (lbs.)	WT. (lbs.)
10"	219	167	155	132
16"	251	202	185	156
22"	290	242	213	183

*Roller quantities listed for tapered rollers only. 1'-0" long tangents include 4 rollers and 1'-6" long tangents include 6 rollers per tangent.

LINE SHAFT CURVE COUPLINGS

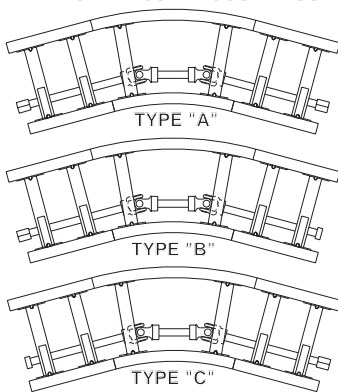

SPECIFICATIONS

TREAD ROLLERS: 1.9" dia. to 1-3/8" dia. x 16 ga. tapered steel, model 138Tw/ 5/16" hex, grooved.

DRIVE BELT: 3/16" dia., polyurethane belts. Nominal 7.5 lbs. per roller drive.

DRIVE SHAFT: 1" dia. C1018 cold rolled steel shaft, located on inside radius. NOTE: Spools are keyed to provide positive drive (designed not to slip on drive shaft).

COUPLINGS: Couplings located both ends (type "A") or one end only (type "B" or "C"). See 'line shaft curve couplings' above and specify.

UNIVERSAL JOINTS: 4 per 90° and 60° curve; 2 per 45° and 30° curve.

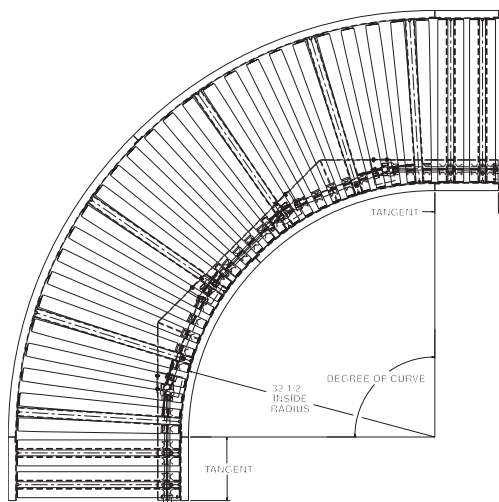

BEARINGS: Precision, lubricated, ball bearing units with composite housings. 6 bearings per 90° and 60° curve; 4 per 45° and 30°.

BED: 7" x 1-1/2" x 12 ga. formed steel channel frame.

TANGENTS: 1'-0" both ends on 60° and 90°; 1'-6" both ends on 30° and 45°. 1'-0" infeed, 1'-0" discharge and no center tangent on 180°. Tangent roller centers 3" RC.

MOTOR DRIVE: Unit is designed to be driven by 738LS.

ELECTRICAL CONTROLS: Optional.

OPTIONAL EQUIPMENT

FLOOR SUPPORTS: Supports, knee braces, casters, polytier supports & ceiling hangers available. See Conveyor Accessories.

GUARD RAILS: 1-3/4" x 1" formed channel (model GC), adjusts horizontally to 8" wider than roller and vertically to 6" above roller; formed steel fixed (model FSG in 2", 4" and 6" heights; fixed channel (model FC); 1-1/2" angle (model GA1-1/2). See Conveyor Accessories.



■ 3 week shipment

MODEL 796LS LINE SHAFT DRIVEN LIVE ROLLER

24 HOUR SHIPMENTS INCLUDE ALL 1-FOOT INCREMENTS 2'-0" TO 100'-0"

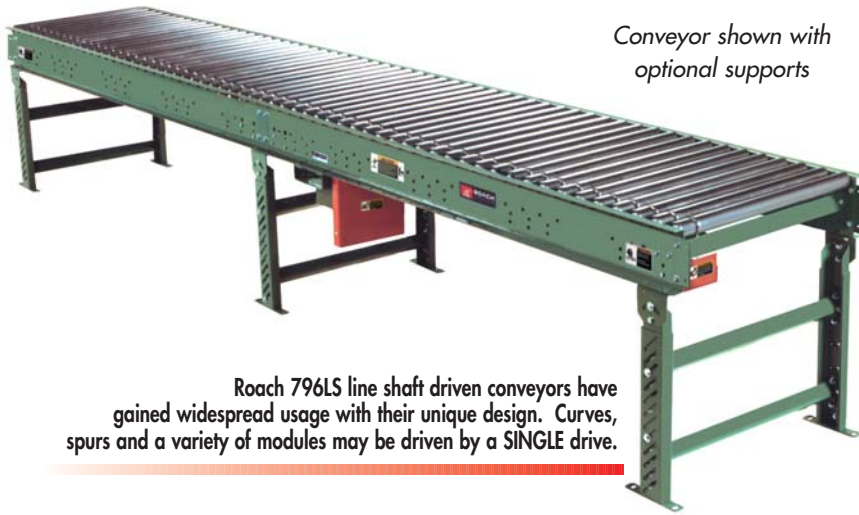

Conveyor shown with optional supports

Roach 796LS line shaft driven conveyors have gained widespread usage with their unique design. Curves, spurs and a variety of modules may be driven by a SINGLE drive.

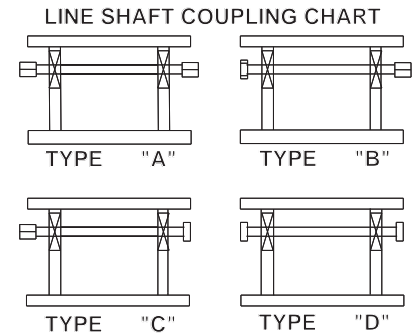
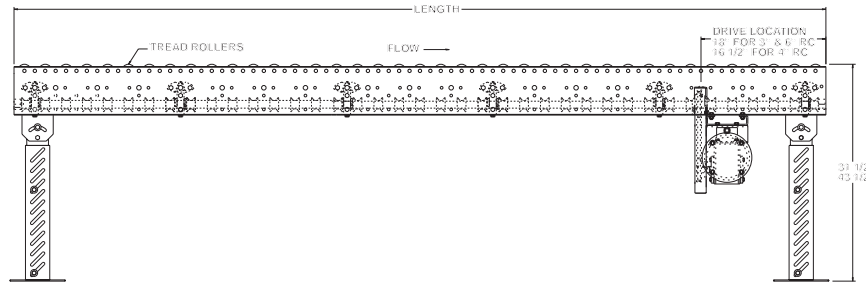
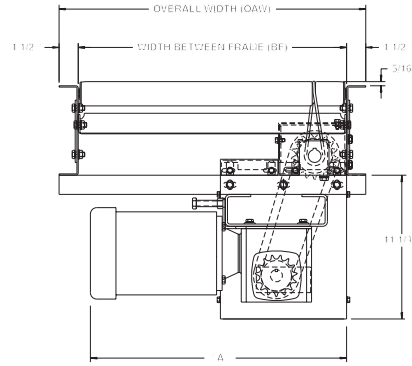

HP @ 60 FPM	"A" MAX.
1/3, 1/2	21"
3/4, 1	22"
1-1/2, 2	23"

SPECIFICATIONS

TREAD ROLLERS: 1.9" dia. x 16 ga. steel, model 196S grooved.

DRIVE BELT: 3/16" dia., polyurethane belts. Nominal 15 lbs. per roller drive.

DRIVE SHAFT: 1" dia. C1018 cold rolled steel shaft.

COUPLINGS: Couplings located both ends (type "A"), one end only (type "B" or "C") or none (type "D"). See 'line shaft coupling chart' and specify.

CENTER DRIVE: Reversible drive; located approximately 18" from end of bed section for 3" and 6" RC; 16-1/2" for 4" RC.

BEARINGS: Precision, lubricated, ball bearing units with composite housings.

SPEED: 60 FPM, constant.

BED: 7" x 1-1/2" x 12 ga. formed steel channel frame. Bed sections attached with splice plates and floor supports.

MOTOR DRIVE: 1/3 HP, 230/460/3, 60 cycle, ODP right angle gear motor.

ROLLER CHAIN: Drive shaft is driven by No. 50 chain. Chain take-up provided on motor base.

CAPACITY: See Technical Section for load capacity rating.

ELECTRICAL CONTROLS: Optional.



■ 24 hour shipment

SPECIFICATION TABLE

CONVEYOR LENGTH		2'	5'	10'	15'	20'	25'	30'	40'	50'	60'	70'	80'	90'	100'
BF	OAW	Unit weights (lbs.) with 3" roller centers (For other centers, deduct weights below)													
15"	18"	225	306	443	552	717	826	991	1265	1539	1813	2087	2361	2635	2909
19"	22"	236	326	475	624	773	922	1071	1369	1667	1965	2263	2561	2859	3157
21"	24"	249	345	495	655	815	1013	1135	1455	1775	2095	2415	2735	3055	3375
25"	28"	255	363	523	693	853	1018	1183	1513	1843	2173	2503	2833	3163	3493
27"	30"	260	374	545	716	887	1058	1229	1571	1913	2255	2597	2939	3281	3623
33"	36"	269	401	588	775	962	1149	1336	1710	2084	2458	2832	3206	3580	3954
39"	42"	288	438	643	848	1053	1258	1463	1873	2283	2693	3103	3513	3923	4333

Deduct the following weights (lbs.) for other than 3" centers

TREAD ROLLER CENTERS	15" BF		19" BF		21" BF		25" BF		27" BF		33" BF		39" BF	
	Per 5'	Per 10'	Per 5'	Per 10'	Per 5'	Per 10'	Per 5'	Per 10'	Per 5'	Per 10'	Per 5'	Per 10'	Per 5'	Per 10'
4"	-14	-28	-17	-34	-19	-37	-21	-42	-23	-45	-27	-53	-31	-62
6"	-28	-56	-34	-68	-37	-74	-42	-84	-45	-90	-53	-106	-62	-124

OPTIONAL EQUIPMENT

SIDE MOUNTED DRIVE: Provides overall conveyor height of 10".

FLOOR SUPPORTS: Supports, knee braces, casters and polytier supports available. See Conveyor Accessories.

CEILING HANGERS: 5/8" dia. threaded rod with hardware to attach rods to conveyor. Provides 6' clearance between ceiling and TOR (furnished in place of floor supports). See Conveyor Accessories.

CONVEYOR SPEED: Constant speed 15-120 FPM; DC variable speed; AC inverter variable speed. **MINIMUM** operating speed for line shaft conveyor is 15 FPM.

GALVANIZED ROLLERS: Tread rollers available in galv. steel, model 196G.

GUARD RAILS: 1-3/4" x 1" formed channel (model GC), adjusts horizontally to 8" wider than roller and vertically to 6" above roller; formed steel fixed (model FSG in 2", 4" and 6" heights; fixed channel (model FC); 1-1/2" angle (model GA1-1/2). See Conveyor Accessories.

MOTORS: Available through 2 HP in TEFC, explosion proof, dirty duty, 115/230/1, 575/3, etc.

ELECTRICAL CONTROLS: Magnetic starter (one direction or reversible); One direction manual starter; Momentary start/stop push button station; Forward/reversing /stop push button. Mounting and pre-wiring for units up to 12' long.

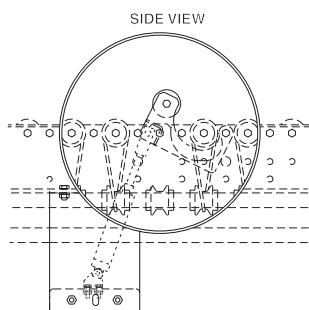

OPTIONAL PNEUMATIC ROLLER STOP

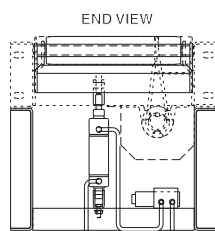

LINE SHAFT BEARING HOUSING

MODEL 796LSC LINE SHAFT DRIVEN CURVE MODULE

24 HOUR SHIPMENTS INCLUDE 30°, 45°, 60° AND 90° MODULES



Conveyor shown with optional supports

Roach line shaft driven curve, module 796LSC, features tapered rollers to help maintain product orientation and is designed to be driven from 796LS line shaft driven conveyor, thus reducing the overall number of drives required.

LINE SHAFT CURVE COUPLINGS

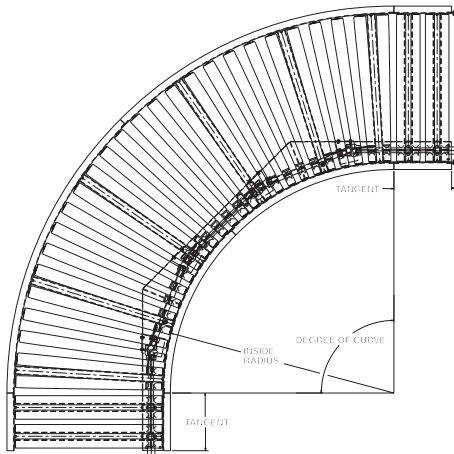
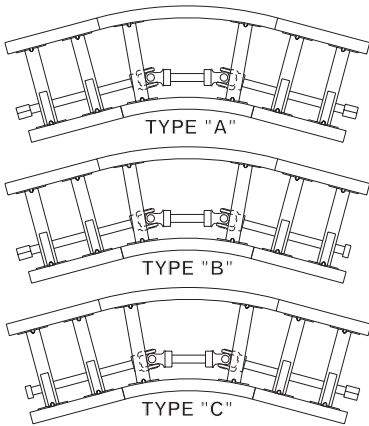

SPECIFICATIONS

TREAD ROLLERS: 2-1/2" dia. to 1-11/16" dia. x 14 ga. steel tapered rollers, model 254T.

DRIVE BELT: 3/16" dia., polyurethane belts. Nominal 15 lbs. per roller drive.

DRIVE SHAFT: 1" dia. C1018 cold rolled steel shaft, located on inside radius. NOTE: Spools are keyed to provide positive drive (designed not to slip on drive shaft).

COUPLINGS: Couplings located both ends (type "A") or one end only (type "B" or "C"). See 'line shaft curve couplings' above and specify.

TANGENTS: 1'-0" both ends on 60° and 90°; 1'-6" both ends on 30° and 45°. 1'-0" infeed, 1'-0" discharge and no center tangent on 180°. Tangent roller centers 3" RC.

BEARINGS: Precision, lubricated, ball bearing units with steel housings. 6 per 90° and 60° curve; 4 per 45° and 30°.

UNIVERSAL JOINTS: 4 per 90° and 60° curve; 2 per 45° and 30° curve.

BED: 7" x 1-1/2" x 12 ga. formed steel channel frame.

MOTOR DRIVE: Driven by 796LS.

SPECIFY MODEL NUMBER PER EXAMPLE

796LSC090-21-1212*

796LSC(curve degree)-(between frames)-(left tangent length, right tangent length)

Available in 30°, 45°, 60°, 90° and 180°.

*Not required for 180° curves. ONLY specify center tangent length if center tangent required (center tangent not available in 24 hour shipment).

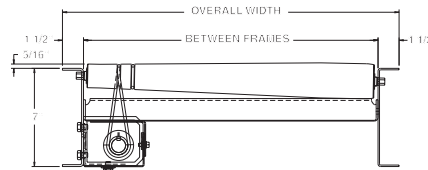

OPTIONAL EQUIPMENT

FLOOR SUPPORTS: See Conveyor Accessories.

GUARD RAILS: See Conveyor Accessories.

BF	INSIDE RADIUS	IR/RC OR/RC	ROLLER CENTERS			
			30°	45°	60°	90°
15"	32-1/2"	IR/RC OR/RC	2.84" 4.15"	2.84" 4.15"	2.84" 4.15"	2.84" 4.15"
19"	32-1/2"	IR/RC OR/RC	2.84" 4.49"	2.84" 4.49"	2.84" 4.49"	2.84" 4.49"
21"	32-1/2"	IR/RC OR/RC	2.84" 4.67"	2.84" 4.67"	2.84" 4.67"	2.84" 4.67"
25"	32-1/2"	IR/RC OR/RC	2.84" 5.02"	2.84" 5.02"	2.84" 5.02"	2.84" 5.02"
27"	32-1/2"	IR/RC OR/RC	2.84" 5.19"	2.84" 5.19"	2.84" 5.19"	2.84" 5.19"
33"	48"	IR/RC OR/RC	3.14" 5.30"	2.90" 4.89"	3.14" 5.30"	2.90" 4.89"
39"	48"	IR/RC OR/RC	3.14" 5.69"	2.90" 5.26"	3.14" 5.69"	2.90" 5.26"

CURVE	180°		90°		60°		45°		30°	
	BF	TAPERED ROLLERS* WT. (LBS.)	TAPERED ROLLERS* WT. (LBS.)	TAPERED ROLLERS* WT. (LBS.)	TAPERED ROLLERS* WT. (LBS.)	TAPERED ROLLERS* WT. (LBS.)	TAPERED ROLLERS* WT. (LBS.)	TAPERED ROLLERS* WT. (LBS.)	TAPERED ROLLERS* WT. (LBS.)	
15"	36	596	18	323	12	270	9	263	6	246
19"	36	638	18	348	12	301	9	293	6	266
21"	36	700	18	381	12	322	9	316	6	287
25"	36	748	18	408	12	349	9	340	6	309
27"	36	794	18	432	12	369	9	362	6	325
33"	52	1070	26	578	16	451	13	442	8	385
39"	52	1192	26	646	16	511	13	505	8	430

*Roller quantities in tangents: 1'-0" = 4 rollers; 1'-6" = 6 rollers per tangent.



■ 24 hour shipment

MODEL 796LSS LINE SHAFT CONVERGING SPUR MODULE



Conveyor shown with optional supports

Line shaft converging spur modules, model 796LSS, allow product to flow from spur lines and merge onto straight line shaft driven conveyor. Spur modules are designed to be driven by 796LS, thus decreasing overall number of drives in the conveyor system.

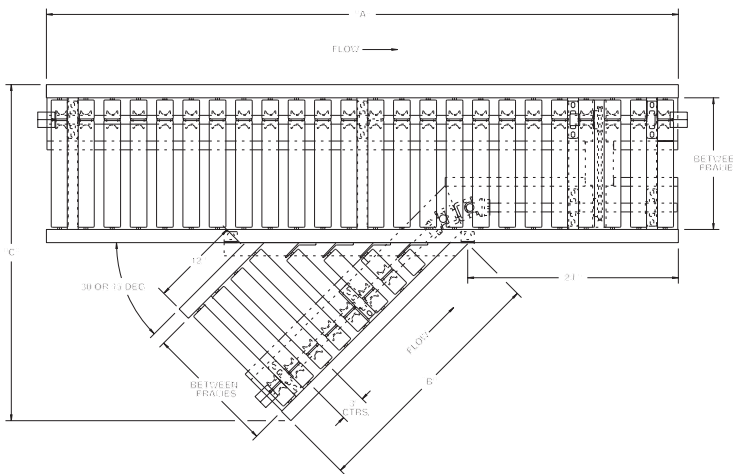

SPECIFY MODEL NUMBER PER EXAMPLE

796LSS-45-21-R

796LSS-(spur degree)-(between frames)-(left or right)

Available in 30° or 45°. Specify 796LSSO for spur module only less mainline module (similar to photo below).



Model 796LSSOX, spur only with powered crossover, shown above.

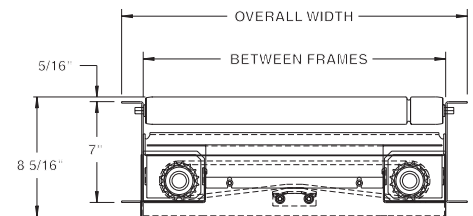

BF	15"	19"	21"	25"	27"	33"	39"
SPUR	UNIT WEIGHTS (lbs.)						
45°	215	234	244	271	285	391	417
30°	230	249	264	372	392	521	619

SPECIFICATIONS

TREAD ROLLERS: 1.9" dia. x 16 ga. steel, model 196S grooved, 3" centers.

DRIVE BELT: 3/16" dia., polyurethane belts. Nominal 15 lbs. per roller drive.

DRIVE SHAFT: 1" dia. C1018 cold rolled steel shaft. NOTE: Spools in spur section only are keyed to provide positive drive (designed not to slip on drive shaft).

COUPLINGS: Couplings located both ends or one end only. Specify where couplings required.

BED: 7" x 1-1/2" x 12 ga. formed steel channel frame. Short side of spur is always 12" overall length.

BEARINGS: Precision, lubricated, ball bearing units with composite housings.

MOTOR DRIVE: Unit is designed to be driven by 796LS.

ROLLER CHAIN: Spur driven via crossover with No. 40 chain.

BF	30° SPUR			45° SPUR		
	"A"	"B"	"C"	"A"	"B"	"C"
15"	6'	40-7/8"	38-3/8"	6'	28-5/8"	38-1/4"
19"	8'	47-3/4"	45-7/8"	8'	32-5/8"	45-1/8"
21"	8'	51-1/4"	49-5/8"	8'	34-5/8"	48-1/2"
25"	8'	58-1/8"	57-1/8"	8'	38-5/8"	55-3/8"
27"	8'	61-5/8"	60-3/4"	8'	40-5/8"	58-3/4"
33"	10'	72"	72"	10'	46-5/8"	69"
39"	10'	82-3/8"	83-1/4"	10'	52-5/8"	79-1/4"

OPTIONAL EQUIPMENT

FLOOR SUPPORTS: Supports, knee braces, casters, polytier supports & ceiling hangers available. See Conveyor Accessories.

GUARD RAILS: 1-3/4" x 1" formed channel (model GC), adjusts horizontally to 8" wider than roller and vertically to 6" above roller; formed steel fixed (model FSG in 2", 4" and 6" heights; fixed channel (model FC); 1-1/2" angle (model GA1-1/2). See Conveyor Accessories.

NOTE: Specify "right hand" or "left hand". To determine hand of spur, refer to Technical Section.



■ 4 week shipment

MODEL 796LSDS LINE SHAFT DIVERGING SWITCH MODULE



Conveyor shown with optional supports

796LSDS is used in diverging applications where line shaft conveyor is suitable. The pivot section of rollers, pneumatically actuated, skews to divert packages onto spur quickly and efficiently.

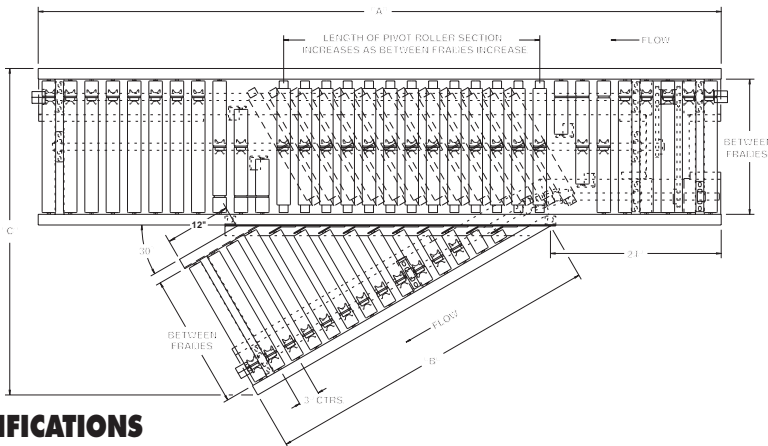
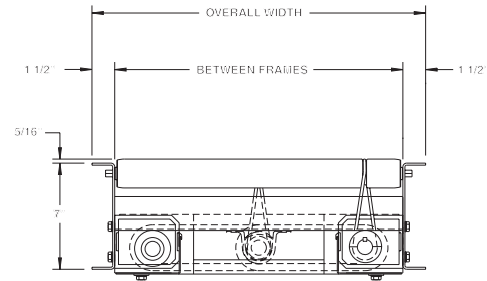

SPECIFICATIONS

TREAD ROLLERS: 1.9" dia. x 16 ga. steel, model 196S grooved.

DRIVE BELT: 3/16" dia., polyurethane belts. Nominal 15 lbs. per roller drive.

DRIVE SHAFT: 1" dia. C1018 cold rolled steel shaft. NOTE: Spools in spur and spools in pivot roller section are keyed to provide positive drive (designed not to slip on drive shaft).

COUPLINGS: Couplings located both ends or one end only. Specify where couplings required.

BED: 7" x 1-1/2" x 12 ga. formed steel channel frame. Short side of spur is always 12" overall length.

ROLLER CHAIN: Spur driven via crossover with No. 40 chain.

BEARINGS: Precision, lubricated, ball bearing units with composite housings.

PNEUMATICALLY ACTUATED: Diverging section of rollers is pneumatically actuated utilizing 60PSI maximum.

MOTOR DRIVE: Unit is designed to be driven by 796LS.

DIRECTION OF FLOW: Specify right hand or left hand. To determine hand of spur, refer to pg. 136 in technical section.

MINIMUM PACKAGE SIZE: Consult factory for minimum package size (minimum size may vary based on conveyor width).

OPTIONAL EQUIPMENT

FLOOR SUPPORTS: Supports, knee braces, casters, polytier supports & ceiling hangers available. See Conveyor Accessories.

GUARD RAILS: 1-3/4" x 1" formed channel (model GC), adjusts horizontally to 8" wider than roller and vertically to 6" above roller; formed steel fixed (model FSG in 2", 4" and 6" heights; fixed channel (model FC); 1-1/2" angle (model GA1-1/2). See Conveyor Accessories.

BF	"A"	"B"	"C"	WT. (lbs.)
15"	6'-0"	40-7/8"	38-3/8"	290
19"	8'-0"	47-3/4"	45-7/8"	310
21"	8'-0"	51-1/4"	49-5/8"	325
25"	8'-0"	58-1/8"	57-1/8"	380
27"	8'-0"	61-5/8"	60-3/4"	526
33"	10'-0"	72"	72"	586
39"	10'-0"	82-3/8"	83-1/4"	678

NOTE: This unit is not designed for high-rate sortation. Consult factory for high-rate applications.

■ 4 week shipment



MODEL 796LSG LINE SHAFT GATE MODULE

Conveyor shown with
optional supports



Model 796LSG offers the ultimate versatility--it is driven by 796LS so no drive is required and it offers operator accessibility eliminating dangerous walk-overs.

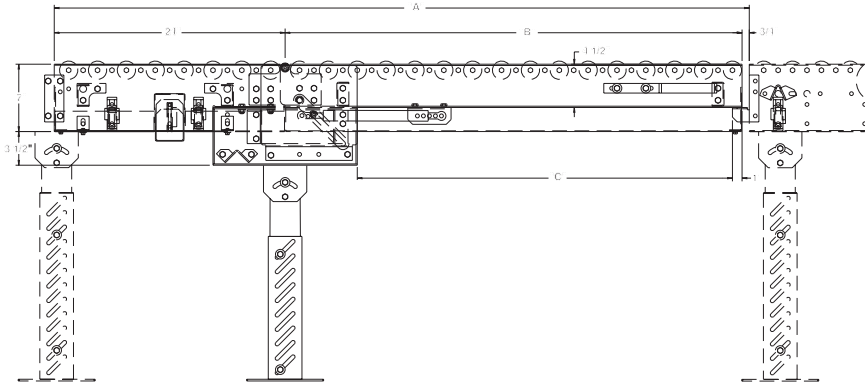
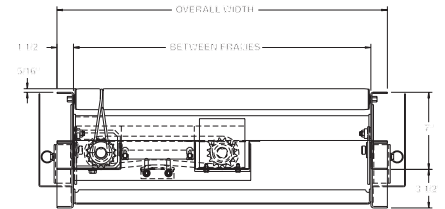

OPTIONAL EQUIPMENT

FLOOR SUPPORTS: Supports, knee braces, casters, polytier supports & ceiling hangers available. See Conveyor Accessories.

GUARD RAILS: Consult factory for guard rails to be used with line shaft gate module.

SPECIFICATIONS

TREAD ROLLERS: 1.9" dia. x 16 ga. steel, model 196S grooved.

DRIVE BELT: 3/16" dia., polyurethane belts. Nominal 15 lbs. per roller drive.

DRIVE SHAFT: 1" dia. C1018 cold rolled steel shaft, located on long side of spur.

COUPLINGS: Couplings located on horizontal sections only.

LIFT: Gas cylinder provides assist for raising/lowering.

BEARINGS: Precision, lubricated, ball bearing units with composite housings.

BED: 4-1/2" x 1-1/2" x 10 ga. formed steel channel frame on actual lift gate; 7" x 1-1/2" x 12 ga. on 2' horizontal section.

MOTOR DRIVE: Unit is designed to be driven by 796LS.

SPECIFY HAND: Specify if gate is left hand or right hand.

GATE LENGTHS/OPENINGS

GATE	"A"	"B"	"C"
5'	60-1/4"	35-1/2"	26-7/8"
6'	72-1/4"	47-1/2"	38-7/8"
7'	84-1/4"	59-1/2"	50-7/8"

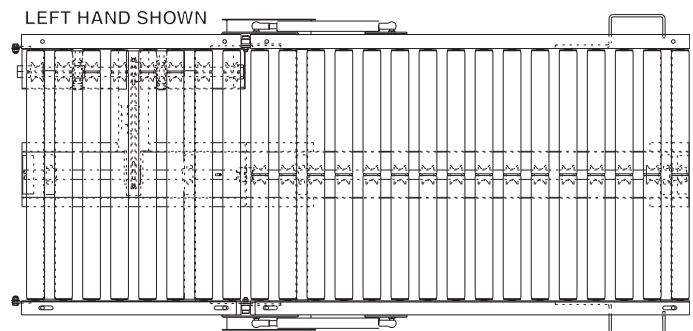

■ 4 week shipment

MODEL 796LSX LINE SHAFT CROSS-OVER MODULE

24 HOUR SHIPMENTS INCLUDE ALL 1-FOOT INCREMENTS 2'-0" TO 10'-0"



Conveyor shown with optional supports

Roach cross-over module 796LSX was designed to offer a standard component to eliminate confusion over cross-overs. Available in 2'-10' lengths in 24 hours, Roach model 796LSX is the only component required to cross over drive shaft.

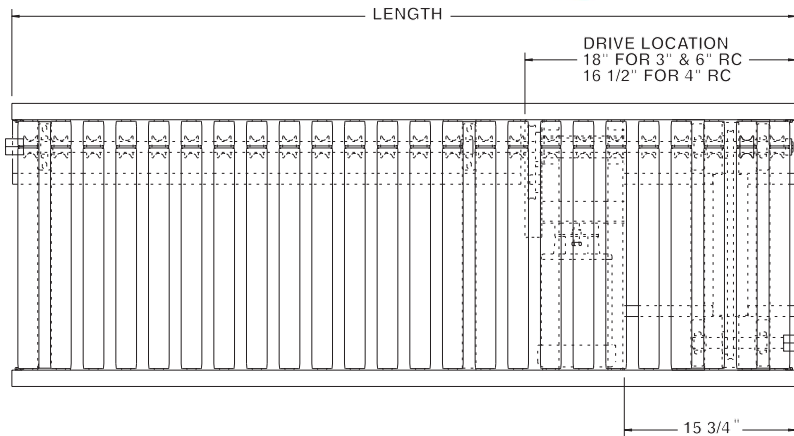

SPECIFICATIONS

TREAD ROLLERS: 1.9" dia. x 16 ga. steel, model 196S grooved.

DRIVE BELT: 3/16" dia., polyurethane belts. Nominal 15 lbs. per roller drive.

DRIVE SHAFT: 1" dia. C1018 cold rolled steel shaft.

COUPLINGS: Couplings located both ends or one end only. Specify where couplings required.

BEARINGS: Precision, lubricated, ball bearing units with composite housings.

SPEED: 60 FPM constant.

BED: 7" x 1-1/2" x 12 ga. formed steel channel frame.

MOTOR DRIVE: 1/3 HP, 230/460/3, 60 cycle, ODP right angle gear motor.

CROSS OVER DIRECTION: Specify "cross over to right hand" or "cross over to left hand".

ELECTRICAL CONTROLS: Optional.

SPECIFY MODEL NUMBER PER EXAMPLE

796LSX-21-3-10-R

796LSX-(between frames)-(roller centers)-(length)-(left or right)

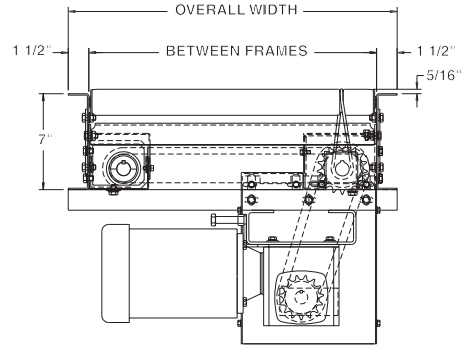

RC	3"	4"	6"	3"	4"	6"
BF	10' UNIT WEIGHTS			UNIT WEIGHTS / FT.		
15"	455	427	389	26	23	20
19"	487	453	419	29	25	22
21"	507	470	433	31	27	24
25"	536	494	451	35	31	27
27"	558	513	468	37	33	28
33"	601	548	495	43	39	32
39"	657	595	533	49	43	37

OPTIONAL EQUIPMENT

GUARD RAILS: 1-3/4" x 1" formed channel (model GC), adjusts horizontally to 8" wider than roller and vertically to 6" above roller; formed steel fixed (model FSG in 2", 4" & 6" heights; fixed channel (model FC); 1-1/2" angle (model GA1-1/2). See Conveyor Accessories.

FLOOR SUPPORTS: Supports, knee braces, casters, ceiling hangers and polytier supports available. See Conveyor Accessories.

CONVEYOR SPEED: Constant speed 15-120 FPM; DC variable speed; AC inverter variable speed. MINIMUM operating speed for line shaft conveyor is 15 FPM.

ELECTRICAL CONTROLS: Magnetic starter (one direction or reversible); Others available. Consult factory.

■ 24 hour shipment



MODEL RBT3 3-STRAND 90° ROUND BELT TRANSFER



Model RBT3 provides an excellent method of transferring up to 100# product at 90° intervals. And, no drive is necessary when mounted into Roach line shaft driven conveyor. Each unit shown mounted in optional line shaft driven conveyor. Model at right includes optional frame cut-outs and blue paint.

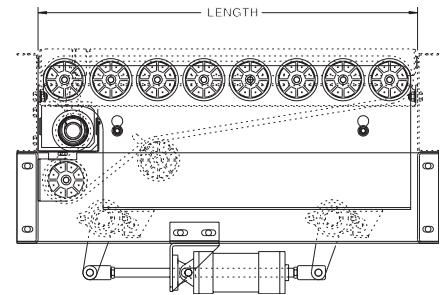
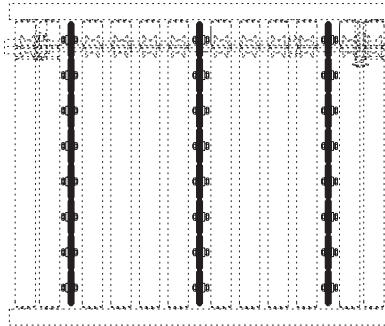
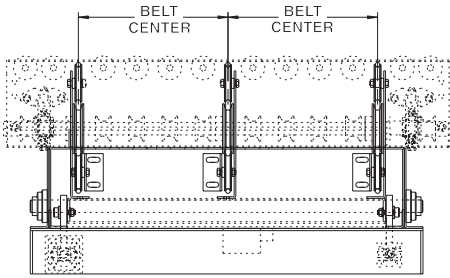

SPECIFICATIONS

TRANSFER ARM: 10 ga. formed channel.

TRANSFER BELT: 3/8" dia. round polyurethane belt.

LENGTHS: Transfer designed to mount in 796LS line shaft conveyors 15"-39" BF.

BELT CENTERS: 12"

ONE DIRECTION FLOW: Transfers product in one direction.

TAKE-UP: Adjustable sheaves provides take-up of transfer belt.

BEARINGS: Heavy duty, lubricated, ball bearing units with cast iron housings.

BELT SPEED: Driven at 150% of speed as powered section transfer is mounted in.

LIFT: 3/4" positive lift.

MOTOR DRIVE: Optional.

CAPACITY: 100 lbs.

AIR CONTROLS: Air cylinder with single solenoid valve. (60-80 PSI required)

FLOOR SUPPORTS: Transfer is designed to attach to 796LS/738LS conveyors w/ mounting hardware integral feature of transfer.

NOTE: Specify twist (clockwise or counter clockwise) for drive bands on line shaft conveyor (model LS or LSA) that transfer mounts in. Consult factory.

BF	WT. (lbs.)	BF	WT. (lbs.)
15"	149	33"	186
21"	165	39"	204

OPTIONAL EQUIPMENT

STRANDS: 2 and 4

BELT CENTER: 18" and 24" with 4" centerline minimum.

MOTOR DRIVE: 1/2 HP, 230/460/3, 60 cycle, ODP right angle gear motor. Other HP and characteristics available such as TEFC, explosion proof, dirty duty, brake motor, 115/230/1, 575/3.

DIRECTION OF FLOW: Reversible.

BELT SPEED: For some speed changes an optional drive may be required. Consult factory.



■ 3 week shipment